

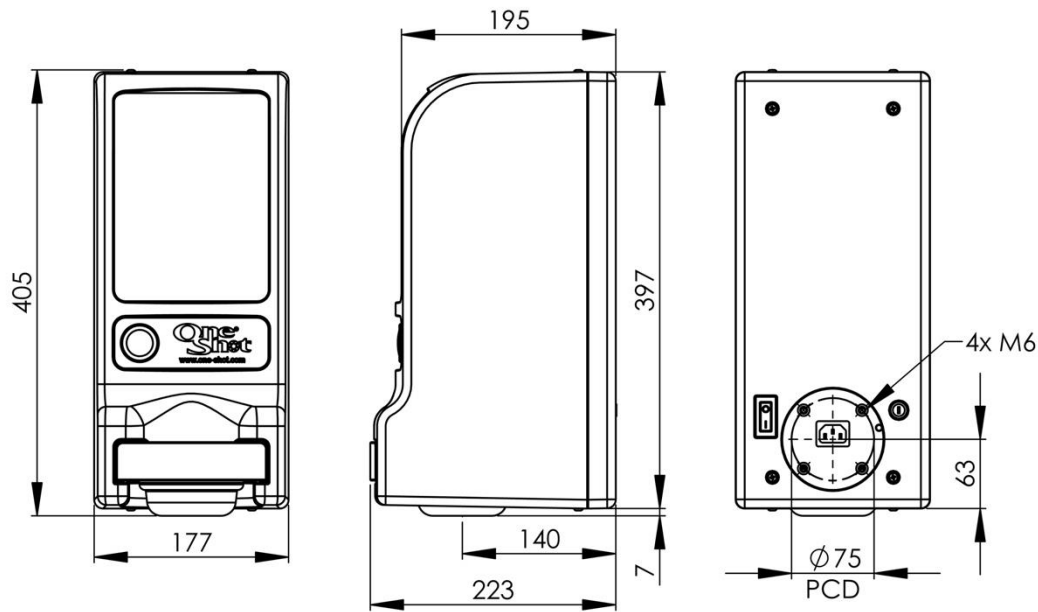

# OS17

## Data Sheet



- Max Power: 100w
- Input Fuse: 2A(T) – 220v/240v  
2A(T) – 100v/120v
- Frequency: 47/63hz
- Input voltage 85-264VAC

### MACHINE DIMENSIONS

- Height: 405mm
- Width: 177mm
- Depth: 223mm
- Net Weight: 8kg

### PACKAGING DIMENSIONS

- Height: 500mm
- Width: 200mm
- Depth: 270mm
- Gross Weight: 9kg



# COUNTER STAND

Data Sheet

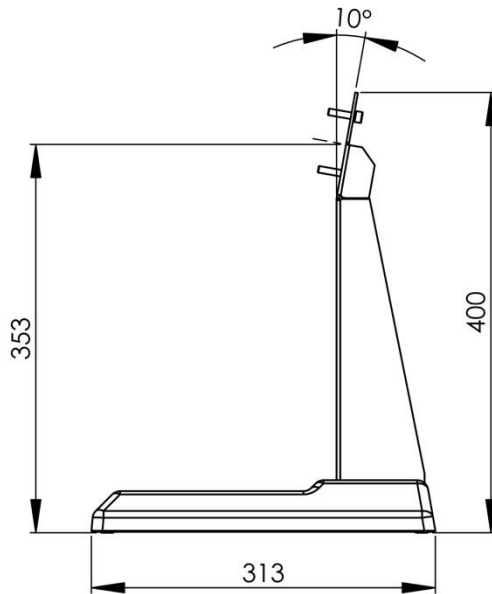
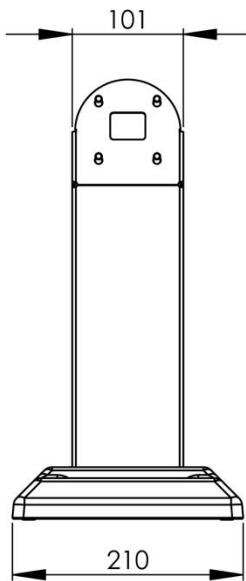
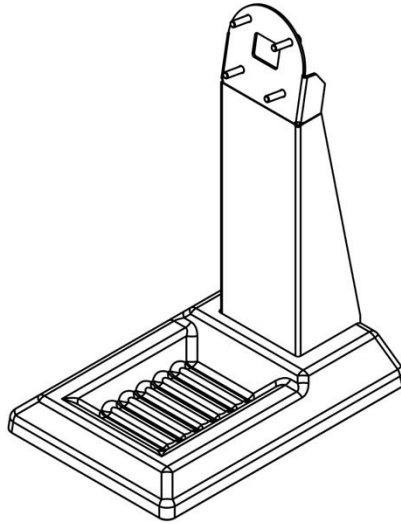
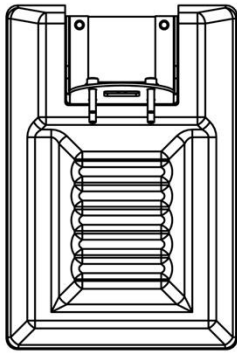

## PACKAGING DIMENSIONS

- Height 400mm
- Width 240mm
- Depth 325mm
- Gross Weight 8kg



## COUNTER STAND

Data Sheet

### MODEL **OS17** ON COUNTER STAND

